

Name: \_\_\_\_\_

# Worksheet Booklet

## Katoomba High School

### Stage 5 (10B)

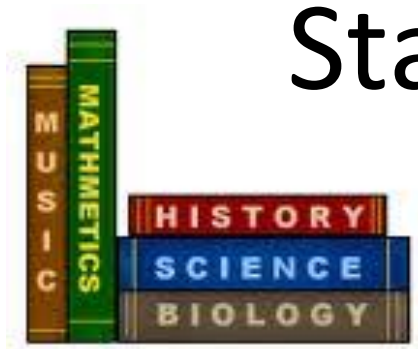

© www.ClipProject.info



#### Instructions

- Complete all the sheets in this booklet
- Write in the space provided
- Hand booklet in to Deputy Principal



Acclaim Images.com

## Sometimes a coach's best words are none at all

After Brisbane had executed the most ruthless and clinical quarter of the AFL season so far last Saturday, an eight-goal-to-one destruction of Collingwood, the usual question was posed: 'I wonder what the coach said to them before the game?'

To those who still glory in the bombastic, heart-tugging addresses of great football orators, the answer will come as a surprise: Lions coach Leigh Matthews said absolutely nothing.

Since taking charge of the back-to-back premiers five years ago, Matthews has abandoned altogether the once compulsory pre-game address. Instead, he holds a meeting 90 minutes before the match and does not speak to the players as a group again until quarter-time.

'I've just come to believe that it [the pre-game speech]

*Source:* R. Hind, 'Sometimes a coach's best words are none at all', *The Sydney Morning Herald*, 16 August 2003, p. 71.

was very over-rated,' he says. 'It isn't really getting a player motivated. It might get them emotionally aroused, but I think real motivation comes with what you do during the week.'

While that approach comes with the approval of the sports scientists, the abandonment of the old-fashioned, pre-match speech is anathema to some. 'That's absolutely not on,' says former Wallabies boss Dave Brockhoff, who was legendary for his stirring addresses and pre-match theatrics. 'You've got to dig deep. I'm sure I was guilty of doing a bit more than that because of my enthusiasm. In team talks I certainly didn't ease off.'

Brockhoff is just one of many coaches credited in football lore with having loosened the hinges on a dressing room door so he could charge through it trying to

inspire his troops before a game (in his case, while coaching Sydney University against Randwick on Anzac Day).

But as romantic as that image seems, players from all football codes are now more likely to wander from the final team meeting in a mood of determined self-control after a reaffirming five-minute chat than enter the arena like a horde of rampaging barbarians.

NSW State of Origin coach Phil Gould says he usually delivers his main address mostly based on tactics before the team leaves the hotel. 'It was different when I played,' he recalls. 'The coaches then would be screaming that the mob next door raped your wife and stole all your worldly possessions. It wasn't until 20 minutes into the game that you remembered you weren't married.'

### Questions

1. What are the two contrasting motivational tactics that the article describes?
2. Discuss whether a coach should need to motivate players or whether they should be self-motivated.
3. Some players may appear uninterested but are still highly motivated. What qualities does a coach need to have to gain the best from players?

.....

.....

.....



# Worksheet 11-01 Brainstarters 11

## Part A: Basic skills (15 marks)

- 1 Draw a regular octagon.
- 2 How many axes of symmetry has a regular octagon?
- 3 Find  $8.52 \div 0.3$ .
- 4  $1 \text{ ha} = \underline{\hspace{2cm}} \text{ m}^2$
- 5 Write 0.037 as a common fraction.
- 6 What is a set square?
- 7 Find the perimeter of a rhombus with side length 7 m.
- 8 Find the area of this triangle.

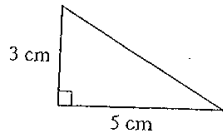

- 9 What is the most general type of quadrilateral that has opposite angles equal?
- 10 Find  $0.8 \times 5$ .
- 11 Classify this triangle:
  - a by sides
  - b by angles
- 12 Write these decimals in descending order:  
**8.501, 8.15, 8.51, 8.5**
- 13 True or false? The diagonals of a rectangle are equal.
- 14 Convert  $\frac{4}{11}$  to a decimal.

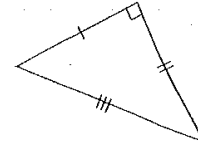

## Part B: Measurement (25 marks)

- 15 Write the time shown on this clock:
  - a in words
  - b in digital time
- 16 Complete:
  - a  $1 \text{ m}^2 = \underline{\hspace{2cm}} \text{ cm}^2$
  - b  $460 \text{ mm} = \underline{\hspace{2cm}}$
  - c  $3 \text{ hours} = \underline{\hspace{2cm}} \text{ minutes}$
  - d  $2.4 \text{ L} = \underline{\hspace{2cm}} \text{ mL}$
- 17 What is the time:
  - a 5 hours after 1:00pm?
  - b 5 hours before 1:00pm?
- 18 Write 4:50pm in 24-hour time.
- 19 Write 2125 hours in 12-hour (am/pm) time.
- 20 Round 7.83 to the nearest whole number.
- 21 How many cubes are needed to make this figure?

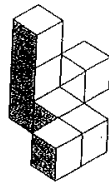
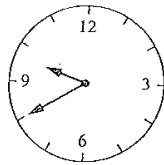

- 22 The first modern Olympic Games were held in 1896 in Greece. How old are the Olympic Games this year?
- 23 Complete:
  - a  $3 \text{ days} = \underline{\hspace{2cm}} \text{ hours}$
  - b  $8.5 \text{ m} = \underline{\hspace{2cm}} \text{ cm}$
  - c  $10.7 \text{ kg} = \underline{\hspace{2cm}} \text{ g}$
  - d  $7500 \text{ mL} = \underline{\hspace{2cm}} \text{ L}$
- 24 Find:
  - a  $45\,200 \div 1000$
  - b  $7.25 \times 1000$
- 25 Convert 450 seconds to minutes and seconds.
- 26 Complete:
  - a  $1 \text{ cm}^2 = \underline{\hspace{2cm}} \text{ mm}^2$
  - b  $4900 \text{ g} = \underline{\hspace{2cm}} \text{ kg}$
  - c  $3 \text{ fortnights} = \underline{\hspace{2cm}} \text{ days}$
- 27 How many hours between 9:00am and 5:00pm?
- 28 What is the value shown by the arrow on this number line?

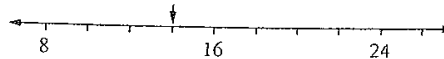

## Challenge (bonus 2 marks)

Lindy wants to bake a cake for 10 minutes but she doesn't have a watch or timer. Instead, she has a 7-minute sandglass and a 4-minute sandglass. How can Lindy use the two sandglasses to time 10 minutes?

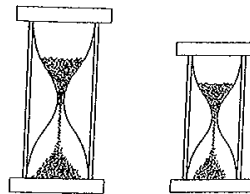

# Blood and its Function

1. Complete the cloze passage using the words below.

transport, clot, RBC's, protect, 8%, platelets, water, oxygen, WBC's, 45%, fluid, 55%, hormones, haemoglobin, scab, germs, leukocytes, clotting

Blood is an integral component of the cardiovascular system, the \_\_\_\_\_ that flows through the vessels, that is pumped by the heart. Blood accounts for about \_\_\_\_\_ of total body weight. Blood consists of \_\_\_\_\_ plasma. Plasma is mostly \_\_\_\_\_ (90%), but also includes dissolved nutrients, proteins, salts, glucose, \_\_\_\_\_, gases and waste products. The function of plasma is to \_\_\_\_\_ these substances as well as the blood cells and their contents around the body.

Blood cells make up \_\_\_\_\_ of blood volume, and 95% of these are red blood cells (\_\_\_\_\_). The red blood cells main function is to carry \_\_\_\_\_ and it does this through the presence of a protein called \_\_\_\_\_. Red blood cells are made in the marrow of bones.

White blood cells (\_\_\_\_\_) or \_\_\_\_\_ come in five different forms, but they all have a similar function, which is to \_\_\_\_\_ the body from disease. White blood cells are also made in the bone marrow.

\_\_\_\_\_ are also formed in the bone marrow, and they are small cells that have the important function of \_\_\_\_\_ the blood. If a person cuts themselves or gets a nose bleed, a protein in the plasma called fibrinogen, constructs long fibres that form a mesh across the hole. The platelets block this mesh and form a \_\_\_\_\_. If this clot is exposed to the air it will form a \_\_\_\_\_. This is the bodies' way of protecting itself from loosing blood, but also preventing \_\_\_\_\_ entering the body.

2. Approximately how much blood does an average adult have?

.....

.....

.....

.....

## Why are they famous?

Match the scientists listed with their achievements.

<i>Johann Kepler</i>	<i>Enrico Fermi</i>
<i>Nicholas Copernicus</i>	<i>Alfred Nobel</i>
<i>Edward Jenner</i>	<i>William Harvey</i>
<i>Louis Pasteur</i>	<i>Joseph Lister</i>
<i>Albert Einstein</i>	<i>Hippocrates</i>
<i>Isaac Newton</i>	<i>Charles Darwin</i>
<i>Gregor Mendel</i>	<i>Galileo Galilei</i>
<i>Wilhelm Roentgen</i>	<i>Marie &amp; Pierre Curie</i>
<i>Carolus Linnaeus</i>	<i>Ernest Rutherford</i>

- 1 Developed system of classifying living organisms. \_\_\_\_\_
- 2 Discovered laws of motion, light and gravity. \_\_\_\_\_
- 3 Astronomer who announced the Earth circled the sun, not the reverse. \_\_\_\_\_
- 4 Discovered how blood circulates. \_\_\_\_\_
- 5 Developed the Theory of Relativity. \_\_\_\_\_
- 6 Credited with inventing dynamite. Began Nobel Prize awards. \_\_\_\_\_
- 7 Presented Theory of Evolution through natural selection. \_\_\_\_\_
- 8 Discovered X-rays. \_\_\_\_\_
- 9 First to develop and perform antiseptic surgery. \_\_\_\_\_
- 10 Recognised heat effectively sterilises, called it 'pasteurisation'. \_\_\_\_\_
- 11 Advanced research in radioactivity, discovered radium and polonium. \_\_\_\_\_
- 12 Discovered vaccine for smallpox. \_\_\_\_\_
- 13 Father of modern genetics, presented principles of heredity. \_\_\_\_\_
- 14 British nuclear physicist, proposed the -Bohr model of the atom. \_\_\_\_\_
- 15 Astronomer/physicist who discovered Laws of Pendulum Motion. \_\_\_\_\_
- 16 Greek physician known as 'The Father of Medicine'. \_\_\_\_\_
- 17 German astronomer, discovered the laws of planetary motion. \_\_\_\_\_
- 18 Produced the first controlled nuclear reactions. \_\_\_\_\_

# Using Pythagoras' theorem to calculate the unknown sides of right-angled triangles

Pythagoras made many contributions to mathematics, music and philosophy. Calculate the unknown sides of these right-angled triangles, and then match the letter with the answer in the code box to discover what other theory is attributed to Pythagoras. Round your answers to one decimal place where necessary.

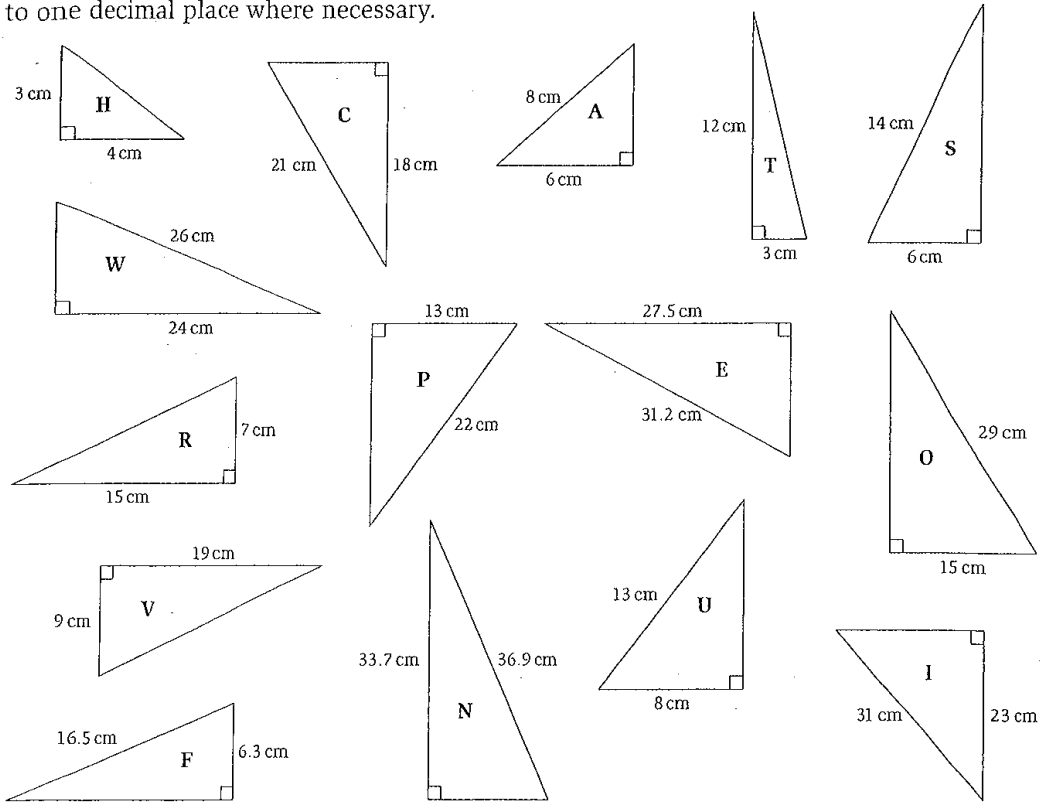

14.7 cm	5.3 cm	16.6 cm	12.4 cm	5 cm

10 cm	5.3 cm	12.6 cm

5.3 cm

12.6 cm	17.7 cm	5 cm	14.7 cm	16.6 cm	14.7 cm

5.3 cm	12.4 cm

12.4 cm	5 cm	14.7 cm

10.8 cm	14.7 cm	15.0 cm	12.4 cm	16.6 cm	14.7 cm

24.8 cm	15.2 cm

12.4 cm	5 cm	14.7 cm

10.2 cm	15.0 cm	20.8 cm	21.0 cm	14.7 cm	16.6 cm	12.6 cm	14.7 cm

Copyright © Lee Blake and Jessica Murphy 2009. Permission is granted for this page to be photocopied by the purchasing institution. Published by Macmillan Education Australia. ISBN 978 1 4202 2886 1





## Salvos help at-risk get on air for a better life

Media is being used as a pathway out of homelessness by the Salvation Army, which has created an internet radio station to provide training opportunities for troubled youth.

The station, at [www.streetradio.net](http://www.streetradio.net), is based at the Army's Oasis youth outreach centre in inner Sydney, and most of its DJs have been homeless.

One of its presenters, 18-year-old Ella Goodman, was sleeping on trains in Sydney and busking at train stations. But she now presents an hour-long radio program each Friday called *Impossible Switch with*

*Ella G*, which covers the world of skateboarding.

Oasis's director Paul Moulds says they are not trying to produce professional DJs but to create a way for the kids to reconnect with the community.

'The biggest issue we have with the kids at Oasis is that even after we stabilise them and get them in accommodation, and their health issues worked out, they still have a sense that there is no way they can find a way back into the big world,' he says.

'So we are trying to create some pathways to get them back into the community — plus it's a fun way of doing it.'

Moulds says some of the program's funding comes from its use as a work-for-the-dole program. 'But alongside that it's available for the young people in the refuge and inner-Sydney generally to get some radio experience.'

The project receives funding from the Sony Foundation, and Australia's music groups have given permission for it to use their music.

Moulds says they are also in discussion to provide the next level of training at Sydney radio station Nova 96.9 FM.

A similar program teaching video production and editing skills has a follow-up course through pay-television group Foxtel, which also broadcasts the videos the young people create on its channels.

Goodman has also completed the video course, and is not yet sure if her future lies in radio. 'It's one of the avenues I can see myself going, the other one being advertising production,' she says.

But before she arrived at Oasis she had bigger priorities. 'I just wanted a roof over my head, quite frankly,' she says.

*Source:* J. Schulze, 'Salvos help at-risk get on air for a better life', *The Australian*, 1 April 2004, p. 17.



Happy on air: Goodman and [www.streetradio.net](http://www.streetradio.net) coordinator James McKay enjoy a lighter moment in the Surry Hills, Sydney, studio.

### Questions

1. Which organisation has set up the project?
2. What health and safety issues is this project helping to address?
3. Which other organisations are supporting the project?
4. How is the project helping to empower young people to improve their lives and remove them from situations in which they are at risk?



EXERCISE

23

# Analysing an Experiment — Bouncing Balls

## Objectives

To improve skills in

- analysing the results of an experiment in order to —
  - (i) derive a logical purpose for the experiment
  - (ii) derive a possible method by which the experiment might have been done
  - (iii) derive a logical conclusion for the experiment
- reading a graph
- constructing a table of information
- writing point form notes

## Instructions

Look at the graph then answer the questions.

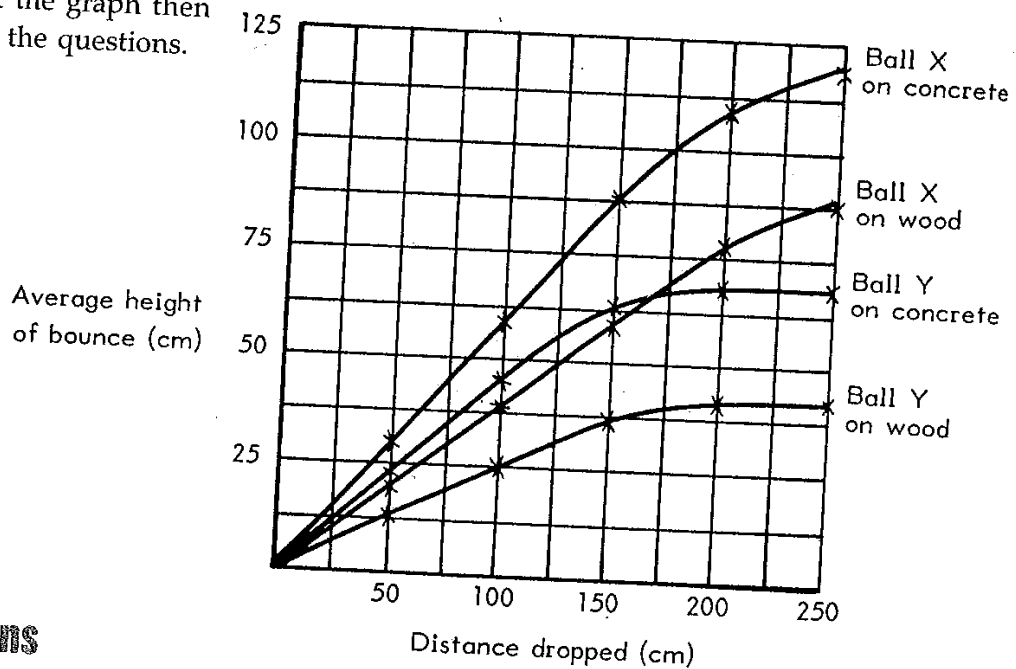

## Questions

1. What do you think was the 'purpose' of this experiment?
2. The graph represents the observations or measurements made by the students doing the experiment. Before drawing it they recorded the measurements in a table. Use the information in the graph to reconstruct that table.
3. Write, in point form notes, a 'method' for this experiment.
4. Write a conclusion for the experiment.



# Worksheet 8-07

# Composite areas

Find the areas of these figures.

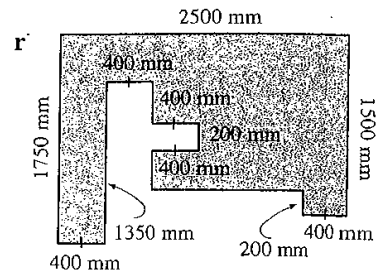
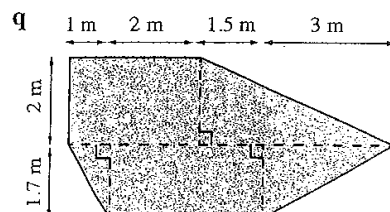
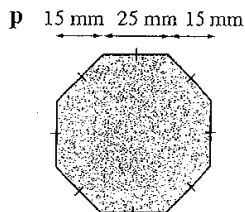
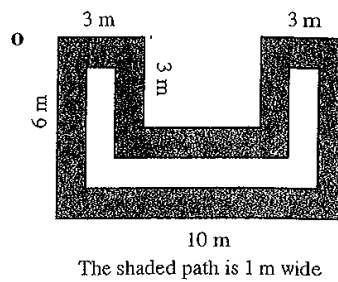
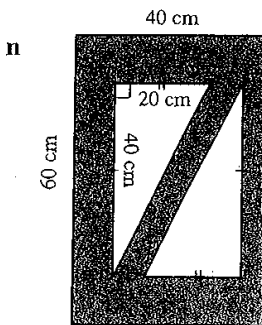
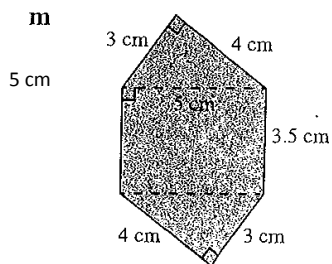
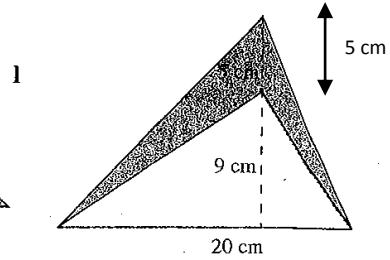
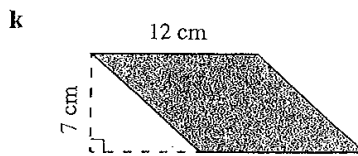
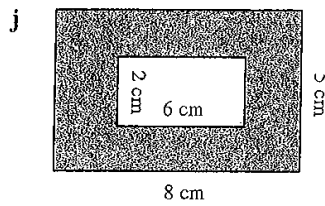
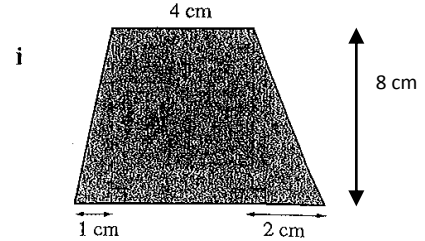
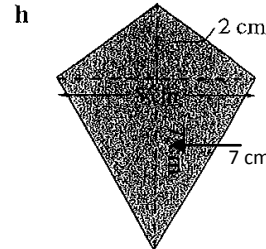
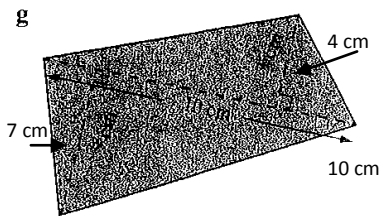
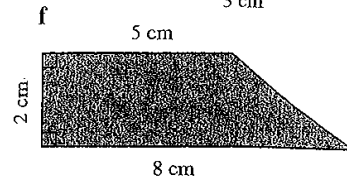
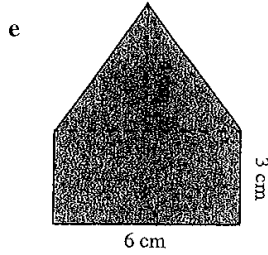
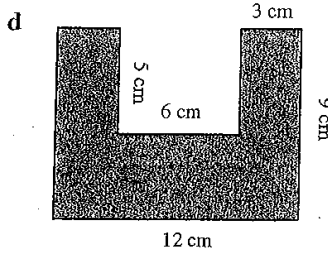
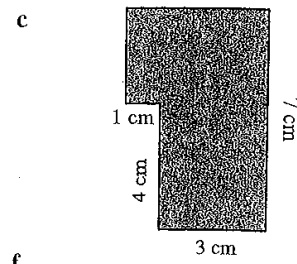
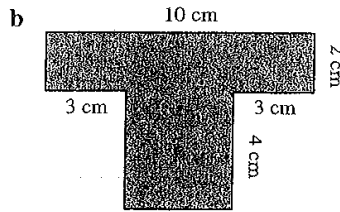
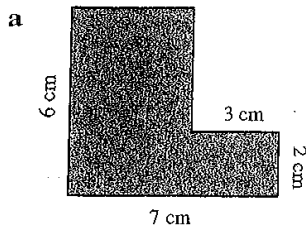





## Binge drinking: now it's a teen epidemic

Binge drinking has reached epidemic proportions among young people, and teenagers from more affluent families may be at greatest risk.

More than a third of teenage boys claimed to have drunk more than 10 drinks in a session in July in a study conducted by Roy Morgan Research for the Salvation Army.

Its report warns the 'massive change' in drinking habits in recent years is a greater worry than illegal drug-taking because it affects so many more people.

'This generation of drinkers starts younger, drinks more, and indulges in binge drinking to a greater extent than any previous generation,' the report says.

'The younger a person is when they start to drink, the more likely they are to drink more than 30 drinks a week,' the report says.

Overall, 63 per cent of teenagers have had their first drink by the age of 14. For the 14–24 age group, the prevalence of binge drinking had grown dramatically in five years; 45 per cent said they had drunk 10 or more drinks on one day the previous month, while in 1997 only 18 per cent had gone on such a binge.

According to the study, 22 per cent of teenage girls had gone on a drinking binge in July, having consumed more than nine drinks in a single four-hour session.

The report based on a sample of 614 Australians aged 14 and over says community acceptance of alcohol, and recent publicity about its positive health affects, has hidden 'the dreadful effects of excessive drinking'.

*Sources:* A. Horin, 'Binge drinking: now it's a teen epidemic', *Sydney Morning Herald*, 4 September 2002, p. 3; The Roy Morgan Association, 'The wild bunch', *Sydney Morning Herald*, 4 September 2002, p. 3.

The young people surveyed said the main reason they drank was to 'fit in at social activities'.

But Paul Dillon, information manager at the National Drug and Alcohol Research Centre, said his work among school children indicated many drank 'to get out of it, to get wasted'.

Mr Dillon said Australia was one of the few countries where binge drinking was acceptable.

In Europe, parents raised their children to use alcohol appropriately. But in Australia concern about illicit drugs had sidelined alcohol as an issue.

'Parents see alcohol use as a protective factor against other drug use,' Mr Dillon said, 'but in reality the only drug problem most will experience with their child will be alcohol.'

He said the rising number of young women who went on alcoholic binges was of concern as their bodies were less able to handle alcohol.

Dr Paul Haber, the head of drug health services at the Royal Prince Alfred Hospital, said binge drinkers were at increased risk of injury and death, pregnancy, sexual abuse, fights and accidents.

'We see large numbers of people admitted to hospitals as a consequence of alcoholic binges,' he said.

'Illicit drug use is also a serious problem but it is much less common.'

Mr Dillon said he had known young binge drinkers to choke on their vomit and die, and to suffer alcoholic toxic poisoning which could also kill them.

Binge drinking is defined as three times the 0.05 blood alcohol rate.

### Questions

- Using the information from the article, create three mind maps to show the possible consequences of binge drinking for:
  - the individual
  - other people
  - the community.
- Identify possible influences on the drinking behaviour of young Australians.
- The study found an increase in binge drinking by young women. Discuss possible reasons for this finding.
- Young people stated that they drank to fit in at social activities. Do you agree or disagree that this is necessary? Justify your answer.





# Volume calculations

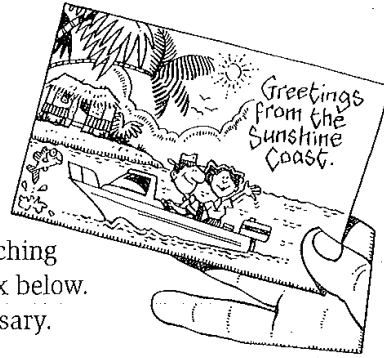

**What is a person who collects postcards called?**

Find the volume of the shapes below. Solve the riddle by matching the letters next to the shapes with the answers in the code box below. Give your answers correct to one decimal place where necessary.

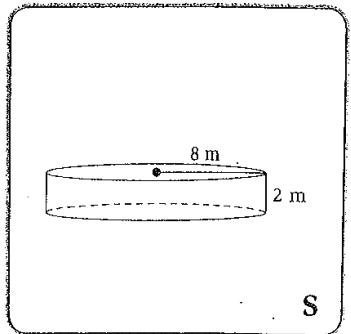
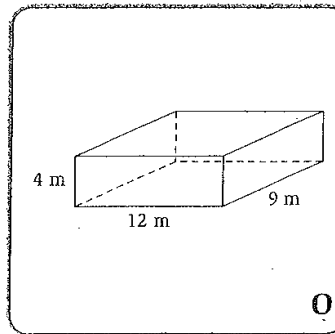
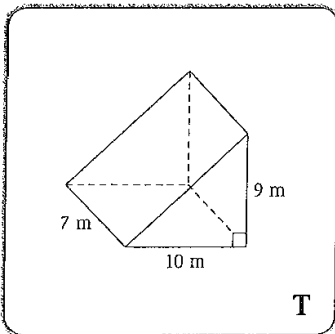
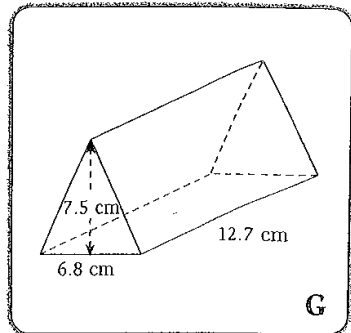
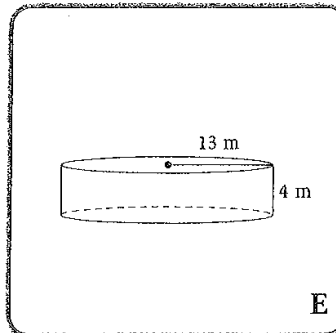
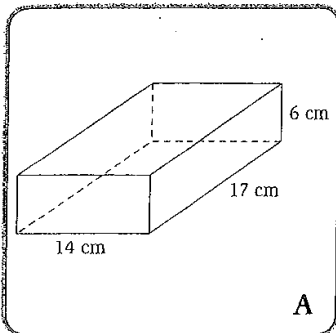
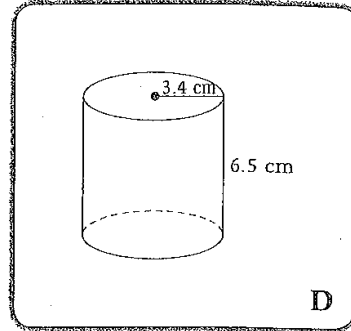
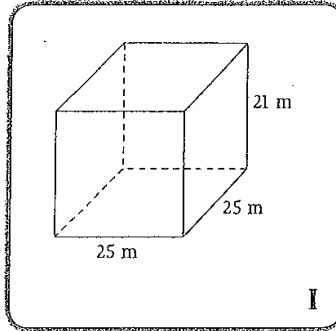
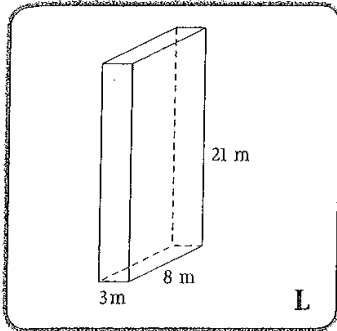

1428 cm <sup>3</sup>

236.1 cm <sup>3</sup>	2123.7 m <sup>3</sup>	504 m <sup>3</sup>	315 m <sup>3</sup>	13 125 m <sup>3</sup>	432 m <sup>3</sup>	504 m <sup>3</sup>	432 m <sup>3</sup>	323.9 cm <sup>3</sup>	13 125 m <sup>3</sup>	402.1 m <sup>3</sup>	315 m <sup>3</sup>



## Assignment 29: A Substitute for Blood

In 1979 Haldor Mickelson lay dying of severe anaemia (lack of blood). As a Jehovah's Witness he refused a blood transfusion. As a last resort, his surgeon, Robert Anderson, obtained permission to use the newly invented *Fluosol-DA*, an experimental substitute for the oxygen-carrying pigment, haemoglobin, in normal blood. In a few hours he recovered. Within a week Mickelson's own bone marrow began producing new red blood cells (red blood cells normally die at a rate of 150 million per minute in the average adult's body, and are replaced in this way). Mickelson became the first American to receive a transfusion of *Fluosol-DA*. It was all transpired through the lungs and skin within three weeks.

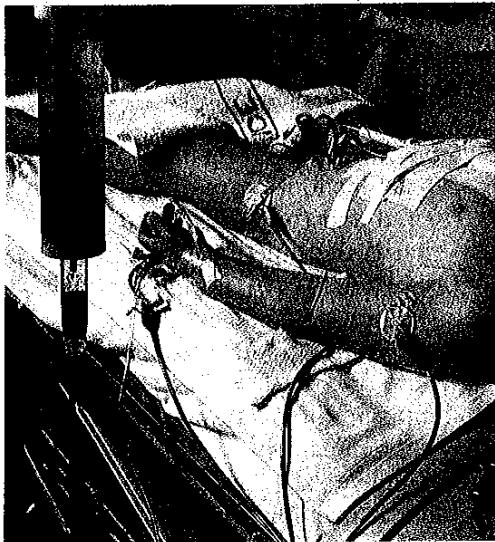

*A blood transfusion*

### Disadvantages

Unfortunately, *Fluosol-DA* lacks the clotting material contained in blood (fibrinogen and platelets). If cut, Mickelson could have bled to death, as would a person with haemophilia, a hereditary condition in which blood fails to clot. *Fluosol-DA* lacks antibodies, special proteins produced by white blood cells to neutralize the foreign proteins (*antigens*) of bacteria, viruses and even organ transplants. It lacks the white blood cells that eat bacteria and consume cells that have died. It is deficient in the hormones and enzymes found in blood. It lacks the colour of blood given it by the red pigment, haemoglobin. Consequently the skin, coloured pink by the blood in the vessels below it, becomes pale — albino animals, instead of having red pupils have white pupils with *Fluosol-DA*. It may even be carcinogenic (cancer causing).

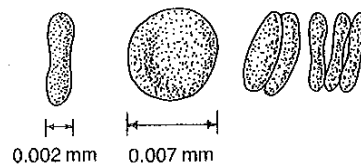

*Red blood cells*

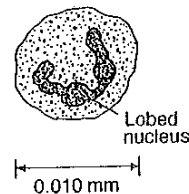

*White blood cells*



**Sterilization**

But it has advantages, too. It can be sterilized, preventing transmission of infectious diseases such as hepatitis and AIDS.

**Carbon monoxide poisoning**

It also has no affinity for carbon monoxide, whereas haemoglobin has a much greater affinity for carbon monoxide than for oxygen. In air containing 0.5 percent carbon monoxide, more than half the haemoglobin in blood is used up, the same, effectively, as losing half one's red blood cells. Fluosol-DA can thus be used to treat carbon monoxide poisoning.

**Compatibility of blood groups**

Fluosol-DA, moreover, is not in any way limited to blood groups. You see, blood occurs in four types we call 'groups' — A, B, AB, and O. Some are 'compatible,' (they mix), while others are not (they clot when mixed). There is another blood grouping involving Rh factors (so-called after the rhesus monkey in which it was first discovered). Most people are Rh-positive (they have the factor) but some (say 15 percent) are Rh-negative and these two types are incompatible. Incompatible blood groups actually attack each other with their antibodies, regarding the foreign blood as an invading protein. People with O-blood type and Rh-negative blood are called universal donors as they can donate blood to anyone. People with AB blood type are universal recipients. Fluosol-DA, however, can be transfused into anyone without an allergic reaction.

	A	B	AB	O
A	✓		✓	
B		✓	✓	
AB			✓	
O	✓	✓	✓	✓

Table 22.1 *Compatibility of blood groups*

**Blue and green blood?**

It is interesting to end on a word about blood in animals other than man. Our blood is red due to the important pigment haemoglobin. Haemoglobin contains iron. It is found in all vertebrates, many annelid worms and insects and some molluscs. However, many creatures have blue blood, due to the copper-containing pigment haemocyanin. It occurs in all crustaceans and most molluscs. Yet others have green blood due to haemocruorin (in some worms) or haemovanadin (in some sea-squirts). Actually, most creatures have no oxygen-carrying pigment in their body fluid or no blood at all.

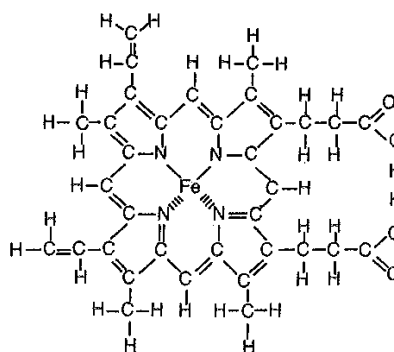

The 'haeme' group of haemoglobin

**Questions**

1. Give at least six functions of blood.
2. What function(s) are carried out by (a) red and (b) white blood cells?
3. What is the function of: (a) platelets (b) fibrinogen?
4. List three advantages of Fluosol-DA over normal blood in transfusions.
5. What are blood groups? How do they complicate blood transfusions?
6. What is meant by a 'universal donor' and 'universal recipient'?
7. What is haemoglobin? (Give as complete a definition as you can.)
8. Is all 'blood' red? Explain.

Lined writing area consisting of multiple horizontal dotted lines.

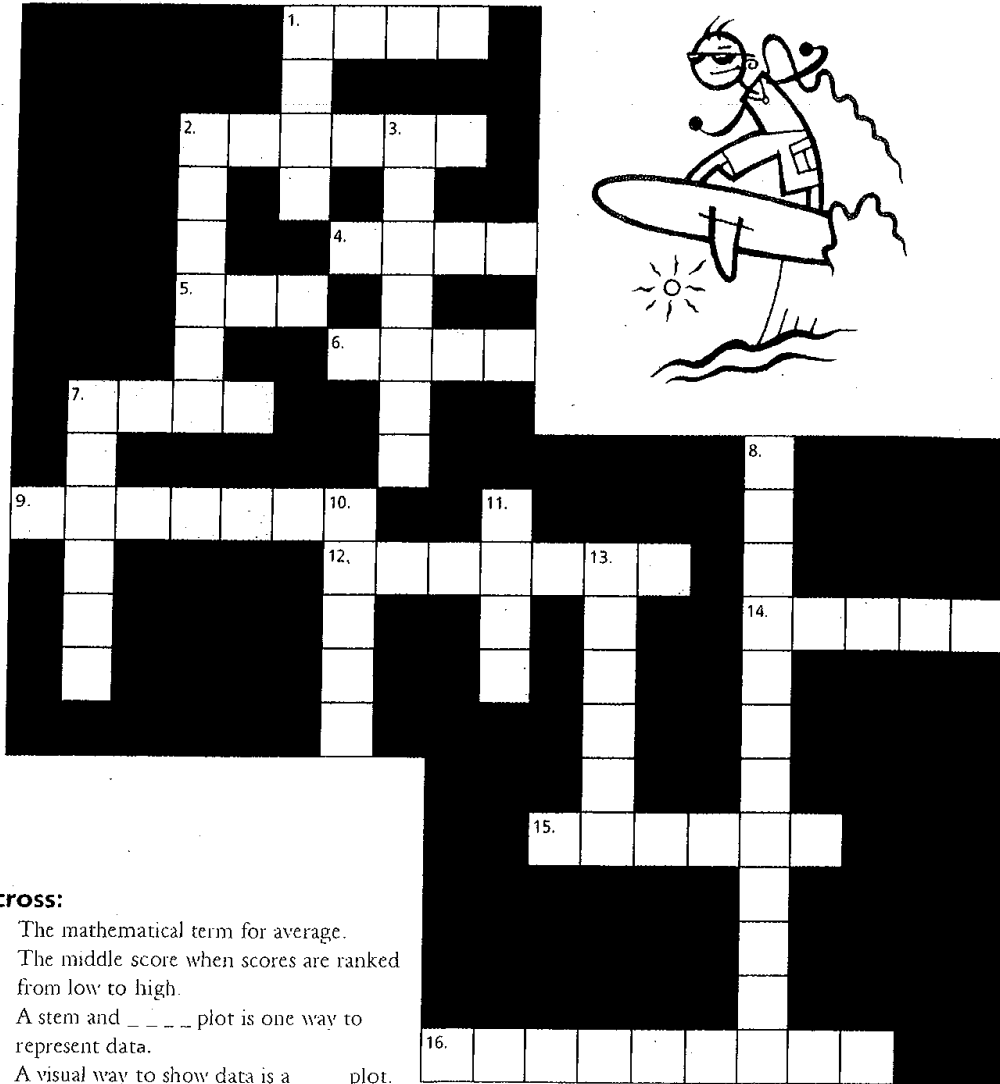

**Across:**

1. The mathematical term for average.
2. The middle score when scores are ranked from low to high.
4. A stem and \_\_\_\_\_ plot is one way to represent data.
5. A visual way to show data is a \_\_\_\_\_ plot.
6. When information is collected in statistics it is called \_\_\_\_\_.
7. In one type of data representation the tens digit is written down the middle and called the \_\_\_\_\_.
9. The mode is the most \_\_\_\_\_ score.
12. To investigate data and interpret it.
14. To organise data we put it in order in a \_\_\_\_\_.
15. When the entire population is surveyed.
16. The number of times a score occurs.

**Down:**

1. The most popular score.
2. The position of the median score.
3. Another word for the mean.
7. The name given to the  $x$  column in a frequency distribution table.
8. When data is collected it is organised in a frequency \_\_\_\_\_ table.
10. Highest score minus lowest score.
11. A stem and leaf \_\_\_\_\_ is a way to show trends in data.
13. Part of the population.