

Name: _____

Worksheet Booklet

Katoomba High School

Stage 5 (9A)



© www.ClipProject.info

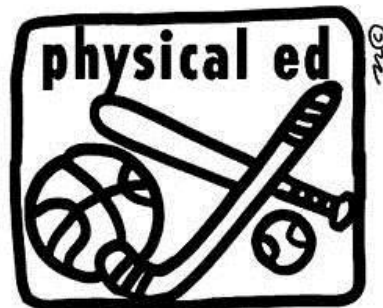

Instructions

- Complete all the sheets in this booklet
- Write in the space provided
- Hand booklet in to Deputy Principal



Acclaim Images.com

STALLED IN SPACE

Following the sequence of ordered pairs below, connect the corresponding points on the graph on page 29. When you reach the word STOP, lift your pencil and start again on the next point in the sequence.

(13, 10)	(28, 35)	(30, 34)	(38, 25)
(20, 10)	(35, 31)	(24, 30)	(27, 25)
(20, 5)	(40, 22)	(25, 25)	(26, 30)
(0, 8)	(35, 15)	(15, 25)	(30, 33)
(0, 10)	(30, 14)	(40, 22)	(32, 33)
(5, 10)	(20, 14)	STOP	STOP
(14, 20)	(25, 20)		
(25, 20)	STOP		
(13, 10)			
(5, 10)			
STOP			

(14, 20)	(10, 33)
(7, 15)	(16, 35)
(5, 18)	STOP
(5, 25)	
(3, 25)	
(0, 28)	
(0, 18)	
(3, 20)	
(5, 20)	
(5, 38)	
(10, 33)	
(5, 28)	
STOP	

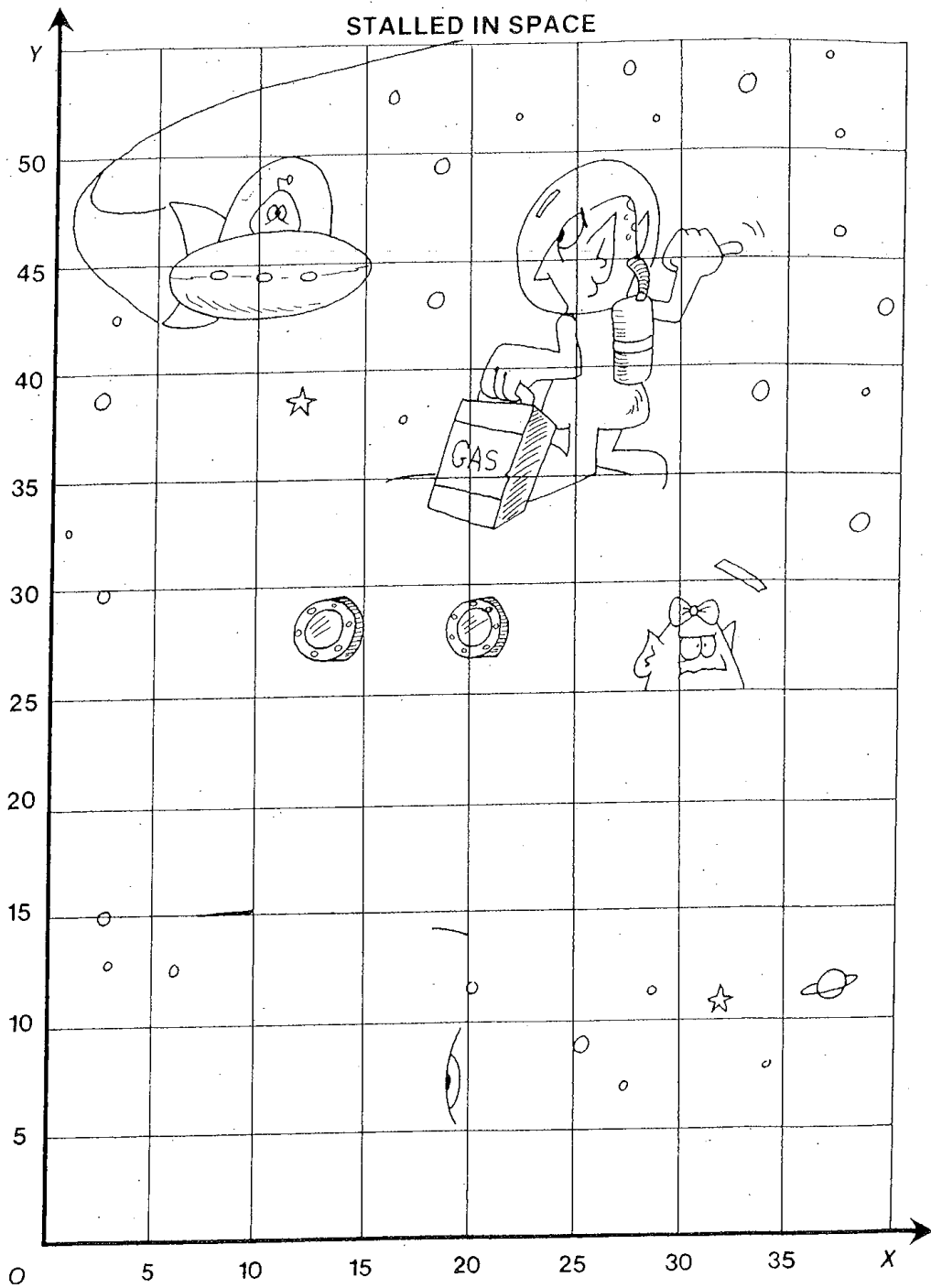

Home Study Unit 6

*It is the little rift within the lute,
That by and by will make the music mute,
And ever widening slowly silence all.*
(Alfred Lord Tennyson)

1 Match the illustration with a **list** word.

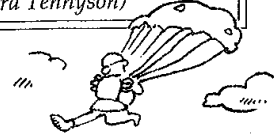
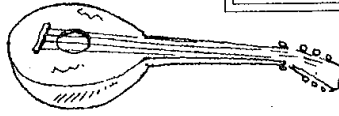
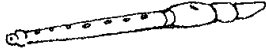

2 Unjumble: sutlaobe _____ tterubi _____
bruteiidst _____ etapruhca _____

3 Write all the **list** words which . . .

- a contain more than 3 vowels _____

- b begin with a consonant _____
- c begin with the first letter of the alphabet _____

4 Complete these sentences . . .

- a A mute person cannot _____ .
- b To play a lute you must _____ it.
- c A parachutist expects his or her chute _____ .
- d A smiling baby is usually thought of as being _____ .
- e A flautist plays a _____ .

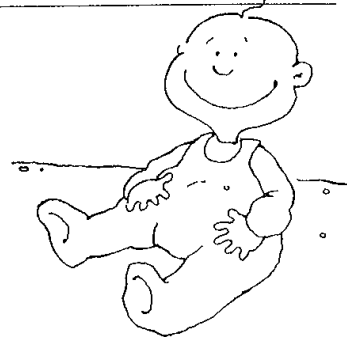

Vocabulary Extension

1 Refuse can also mean rubbish. The accent is shifted to the first syllable so say 'ref-yooce'.

Fuse can also mean to melt together.

Write these two words in sentences using the above meanings.

2 Write the base words which form the following . . .

institution _____ reputation _____ commuter _____

General Knowledge

In classical mythology the Muses were the daughters of the Titan, Mnemosyne, and Zeus, the King of the Gods. Their job was to look after the branches of literature, art and science. Your job is to find out how many Muses there were.

Worksheet 12-03**Collecting like terms**

Simplify each of these algebraic expressions.

- 1 $x + 5x$
- 2 $3y + 8y$
- 3 $6a - a$
- 4 $9t - 4t$
- 5 $3ab + 6ab$
- 6 $8d + 12d$
- 7 $7st + 3st$
- 8 $2x + x$
- 9 $5a^2 + 4a^2$
- 10 $3t - 2t$
- 11 $4ab + 4ab$
- 12 $5ty - 3ty$
- 13 $2mp - mp$
- 14 $x + 4x - 3x$
- 15 $w + w + 5w$
- 16 $2c - 5c$
- 17 $3r - 3r$
- 18 $2m + 3m - m$
- 19 $e - 2e$
- 20 $14h + 6 - 12h$
- 21 $y + y + y$
- 22 $4c + d + 4c - 3d$
- 23 $7p + 2 + 3p + 7$
- 24 $5s - s + 2s$
- 25 $4y^2 + y^2$
- 26 $3d + d - d$
- 27 $a + a + 2f$
- 28 $c + 12d + 2c - 5d$
- 29 $6 + 3h + 4h + 1$
- 30 $6u^2 - 3u^2 + 2u^2$
- 31 $4a + 2a - 6b - 4b$
- 32 $5g - 4 + 2g + 3$
- 33 $10x + 6b - 5b - 7x$
- 34 $12m + 2n + 8m - 7n$
- 37 $12w - 6w + 4wt + 3wt$
- 38 $4a + 6a + 2b - 3a$
- 39 $x^2 + 3y + y + x^2$
- 40 $6f + 3 + 2f + 1$
- 41 $5y^2 + 4x - 2y^2 + 3x$
- 42 $4k + p - 3k + p$
- 43 $x + y - x$
- 44 $8y - 2 - 6y + 1$
- 45 $2y + 3m - y - m$
- 46 $-8 - 2q + 5q + 9$
- 47 $5r^2 + 3r^2 - r - 2r$
- 48 $3a - b + 3a$
- 49 $5t + 3t + 3v - 2v$
- 50 $18 - k + 4k - 10$
- 51 $14b - 2 + 3b - 6$
- 52 $4y + 2z - 3y + z$
- 53 $2x + 5 - 3x - 2$
- 54 $2ab + ab + 3b$
- 55 $2p^2 + 3p - p^2 + p$
- 56 $3u^2 + 5 - u^2 - 4$
- 57 $-5a + 2 + 3a + 3$
- 58 $8x - x - 8$
- 59 $10 + 6x + 3x - 7$
- 60 $9p - 3q - 7p - 2q$
- 61 $8t + 4w - 8t + 2w$
- 62 $15x + 3x - 5 + 5$
- 63 $-4p + 6p + a - 4a$
- 64 $6c + 7d - d - 5c$
- 65 $9jk - 5k - 2kj + 2k$
- 66 $5b - 5 - 12b + 5$
- 67 $-3x + 7y - 7y + 6x$
- 68 $-5y^2 + yz + 3yz - 2y^2$
- 69 $2y + 5 - 6y + 2$
- 70 $7w^2 - 6u + 2w^2 + 9u$

Antoine Laurent Lavoisier (1743–1794) 4a

Educated at the College Mazarin in Paris, Antoine Lavoisier studied mathematics, astronomy, chemistry, botany, and legal studies. His first job was to collect geological information for a map of France. Lavoisier's first published research was on the properties of the mineral gypsum. Later he was awarded a gold medal by the King of France for research on street lighting. Lavoisier worked in a number of areas including the Royal Gunpowder Administration and established the metric system of weights and measures. In 1793 he was arrested by the leaders of the French Revolution because of his involvement in tax collection. Lavoisier was executed by the guillotine.

- 1 (a) What benefits would street lighting have that would lead to Lavoisier being awarded a medal?
(b) Before Lavoisier's time, France had many types of measurements. What advantage does the metric (SI) system have over other types of measurements?
(c) Suggest a reason why Lavoisier was executed by the revolutionaries.

The story so far

In 1597 the first chemical textbook *Alchemia*, by Andreas Libavius, was published. Alchemia or chemistry was defined as the art of 'producing reagents and extracting pure essences from mixtures'. Many new compounds were being prepared at this time by experimenting with animal and vegetable materials. Some of these were alcohol, arsenic, zinc and three strong acids—hydrochloric, sulfuric and nitric. At this time Georg Stahl (1660–1734) proposed the Phlogiston Theory as a way of explaining what happens when substances burn or react with air. Substances that burnt easily such as coal were thought to contain large amounts of phlogiston. (Phlogiston does not actually exist.)

GROUP WORK

- 2 (a) How could you obtain compounds from living material such as a leaf?

LOOK IT UP

- (b) Write the modern formulas for:
 - i hydrochloric acid
 - ii sulfuric acid
 - iii nitric acid
 - iv arsenic
 - v zinc
 - vi alcohol



What did Lavoisier do?

Even though Lavoisier is regarded by many as the founder of modern chemistry, he did not actually discover any new elements or compounds. He did however describe many experiments. In 1772, Lavoisier began a series of experiments that demonstrated the nature of combustion (burning), and proved that the Phlogiston Theory was wrong. From these experiments he concluded that combustion results from the union of a flammable material with the newly discovered gas, oxygen. (Although oxygen had been discovered by Joseph Priestley a few years before, Lavoisier named it and showed that it made up about 20% of the atmospheric air.) Lavoisier accurately presented the chemical knowledge of his time in a chemistry textbook called *Elements of Chemistry* which was published in 1789.

- 3 Describe what you think will happen when the following materials are burned:
 - (a) match
 - (b) match head
 - (c) methylated spirits
 - (d) kerosene
 - (e) wax

4 Some of these materials produce smoke. What is in smoke?

- 5 (a) What main gases make up the atmosphere?
 (b) What are some uses of oxygen?

Lavoisier was very careful in his measurement of the weights of substances involved in chemical reactions. He heated mercury oxide and showed that it released oxygen. The material weighed less after the oxygen had gone. Lavoisier also showed that if mercury was heated at a lower temperature, it would react with oxygen and weigh more.

- 6 (a) Matter never disappears or appears in chemical reactions. Why does mercury (Hg) weigh more when it is heated with oxygen (O) to form mercury oxide (HgO)?
 (b) How much carbon dioxide (CO₂) is formed in the following reaction between carbon (C) and oxygen (O)?



What did Lavoisier conclude?

Using the ideas he developed about the composition of the atmosphere, Lavoisier described what happened in the combustion process in chemical reactions, and what occurred during respiration in living cells. Because of his work we now know that respiration involves the slow, controlled burning of sugar with oxygen in the cells of living things. Respiration also results in the release of the waste product carbon dioxide.

- 8 (a) What is respiration?
 (b) What raw materials are used in respiration?
 (c) What is the main waste product?

As a result of these experiments, Lavoisier defined a chemical element as a substance that could not be decomposed into more simple substances by heat or any chemical reaction. He also defined a compound as a combination of two or more elements in a fixed and definite proportion by weight. Each element was given a number, called combining weight, and it was this number (or any whole number multiple of it) that represented the amount of the element which took part or combined in a chemical reaction.

He developed the first list of 33 elements. This list included lime and magnesia which we now know are not elements. These two substances were later studied by Humphry Davy (1778–1829), who separated the elements calcium and magnesium from them.

- 9 (a) What is an element?
 (b) Give two examples of elements.
 (c) What is a compound?
 (d) List two compounds.
 (e) What elements make up these compounds?

What happened next?

This idea of basing chemical reactions on weight placed chemistry on a quantitative, or measurement, basis. Prior to this chemistry had been qualitative or descriptive only. Lavoisier's work was the start of atomic theory and led, in time, to the chemistry we now know.

- 10 (a) What does the word qualitative mean?
 (b) What does the word quantitative mean?
 (c) How do you think chemistry is a quantitative science?

FITNESS

Find the word or phrase from Column B that best matches the word in Column A

<u>Column A</u>	<u>Column B</u>
1. ___ FITNESS	1. This training technique involves training the energy systems and structures you want to improve.
2. ___ STRENGTH	2. Refers to a person's body shape. Their tendency towards linearity, muscularity or a greater percentage of body fat.
3. ___ FLEXIBILITY	3. A type of aerobic training that involves moving around a number of stations in a set period of time.
4. ___ AGILITY	4. Exercises and activities that place unnecessary strain on the body and may lead to injury.
5. ___ BALANCE	5. The range of movement possible at a joint or group of joints.
6. ___ POWER	6. The ability to use two or more systems of the body to produce smooth, controlled movements.
7. ___ SOCIAL	7. A combination of strength and speed.
8. ___ ENDURANCE	8. This training technique involves placing greater stress on the body for improvements to occur.
9. ___ EMOTIONAL	9. The ability of muscles to repeatedly contract without undue fatigue.
10. ___ FITT	10. The ability to change direction, quickly and under control.
11. ___ OVERLOAD	11. The ability to maintain an active or static position over a base of support.
12. ___ AEROBIC	12. This principle should be applied when planning any training program.
13. ___ SPECIFICITY	13. A benefit of physical activity. Includes less stress, improved self-esteem and better sleep patterns.
14. ___ CIRCUIT	14. The ability to cope with the stresses of everyday life without fatigue.
15. ___ CONTINUOUS	15. A benefit of physical activity. Includes more friends, more social events and greater participation in activities.
16. ___ INTERVAL	16. A type of aerobic training that involves exercising in the aerobic training zone for a minimum of 15-20 minutes.
17. ___ FARTLEK	17. The force that can be applied to a muscle, or group of muscles, during a single contraction.
18. ___ CONTRAINDICATED	18. One of the three energy systems. Carbohydrate is the dominant fuel source and is broken down to provide energy over long periods of time.
19. ___ COORDINATION	19. A training technique that involves exercising at different speeds. For example jog 400m, sprint 50m, jog 400m, sprint 50m etc.
20. ___ SOMATOTYPE	20. A training technique that involves work periods followed by periods of rest.

Area of composite shapes

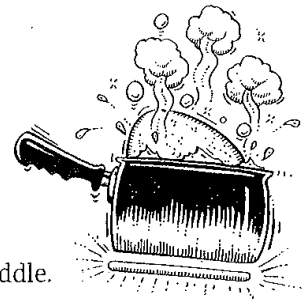

How long would it take to hard boil an ostrich egg?

Find the area of the composite shapes or shaded regions below.
Match the letters with the numbers in the code box to solve the riddle.

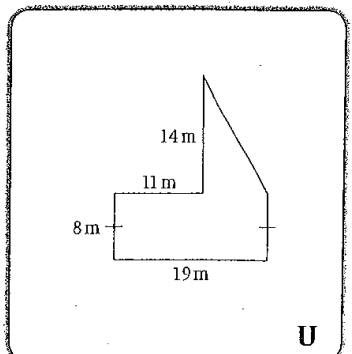
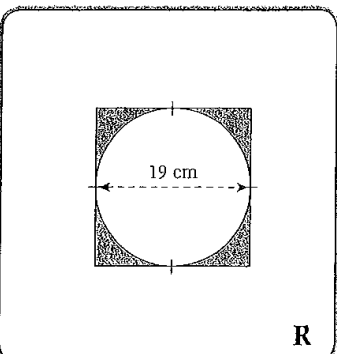
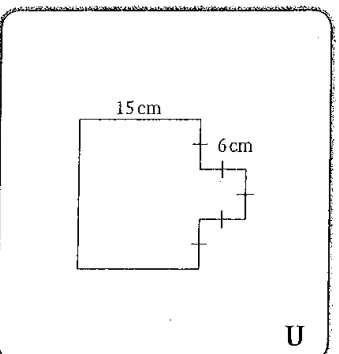
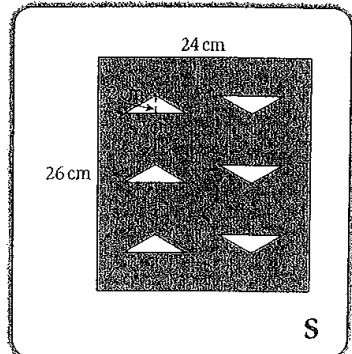
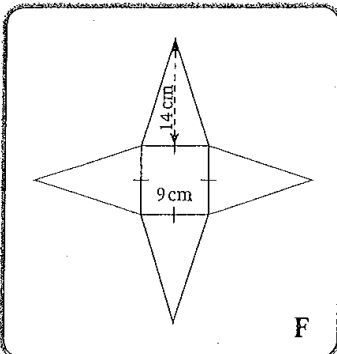
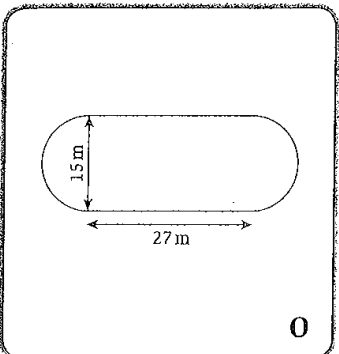
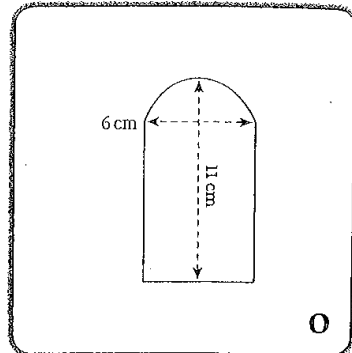
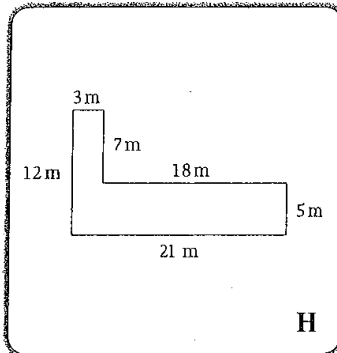
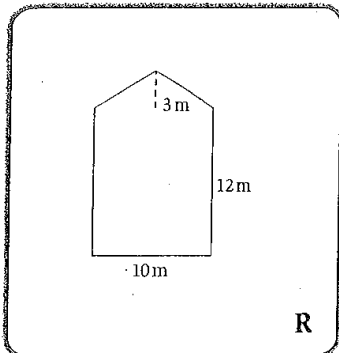

333 cm ²	80.1 cm ²	208 m ²	77.5 cm ²

126 m ²	581.7 m ²	306 cm ²	135 m ²	582 cm ²

A series of horizontal dotted lines spanning the width of the page, intended for writing or drawing.

Basic food web

1 Draw arrows to illustrate the relationships found in this simple food web. Remember, the arrow means 'is eaten by'. The point of your arrow is directed at the organism eaten by whatever is at the base of the arrow.

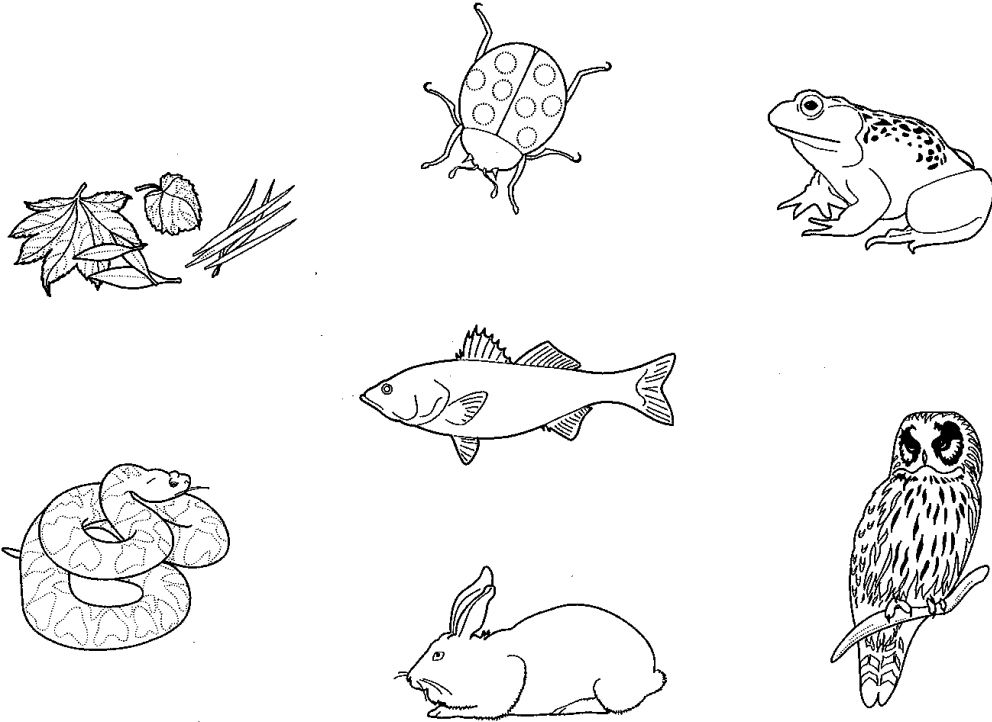

Select one of the organisms above and construct a food web common to the species.

Food pyramids

2 Complete the food pyramid using a food chain from the previous exercise.

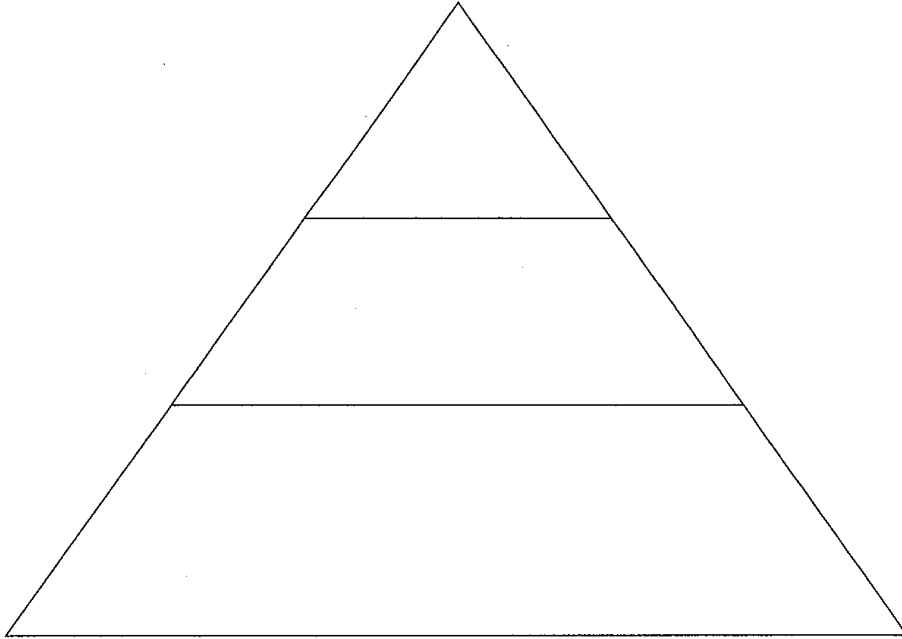

3 What does the pyramid illustrate in terms of biomass of organisms? _____

4 The nine letters in the word square spell a biology theme word. What is it? _____

List 15 smaller words that can be spelled using some of the letters.

The letters can only be used in a word as many times as they appear on the square.

C	S	E
S	E	M
O	T	Y

Worksheet 7-10 Decimals review

Did you know?

- The Chinese of about 2000 years ago used decimals similar to ours.
- In 1492, Francesco Pellos was the first to use the decimal point.

1 Write each fraction as a decimal.

a $\frac{3}{10}$ b $\frac{7}{10}$ c $\frac{13}{100}$ d $\frac{2}{5}$
 e $\frac{1}{2}$ f $\frac{2}{3}$ g $\frac{3}{4}$ h $\frac{81}{100}$
 i $\frac{13}{20}$ j $\frac{9}{1000}$ k $\frac{5}{6}$ l $\frac{2}{7}$

2 Write in decimal form.

a $\frac{7}{10} + \frac{3}{100}$ b $\frac{16}{100} + \frac{2}{1000}$
 c $2 \times 10 + \frac{9}{10}$ d $\frac{4}{10} + \frac{3}{100} + \frac{7}{1000}$
 e $\frac{21}{100} + \frac{15}{10\,000}$ f $13 + \frac{8}{1000}$

3 Write each decimal as a simplified fraction.

a 0.3 b 0.25 c 0.8
 d 0.03 e 0.02 f 0.125
 g 0.16 h 0.35 i 0.101
 j 0.05 k 0.0008 l 0.0025

4 Place these decimals in ascending order:
2.451, 2.54, 2.145, 2.415, 2.5, 2.15, 2.4

5 Evaluate:

a $1.25 + 0.32$ b $13.68 - 0.9$
 c $43.2 \div 8$ d 1.25×3
 e $50 - 13.18 - 7.096$ f $14.4 \div 1.2$
 g $16.35 + 9.28 - 3.831$ h $(1.6 - 0.3) \times 5$
 i $1.2 - 2 \times 0.3$ j $6.4 + 3.7 \times 4$
 k $0.4 \times 0.3 \div 0.2$ l $\sqrt{0.25}$
 m $34.16 \div 8$ n $4.42 \div 0.4$

6 Complete the table by rounding each value to the required number of places.

Round:	to one decimal place	to two decimal places
a 3.2348		
b 12.925		
c 0.9753		
d 0.7811		
e 6.283		
f 36.057		
g 0.01387		
h 99.999		

7 Calculate, correct to one decimal place:

a $(1.06 + 5.43) \times 3.2$
 b $(36 - 12) \div (4.8 + 1.5)$
 c $\frac{1.5 + 6.4}{3.65 - 2.58}$
 d $\frac{12.14 - (3.2 \times 4.1)}{6.51 \div 2.1}$

8 The *Welcome Stranger* gold nugget weighed 78.4 kg. How many gold rings of 35 grams each could be made from this nugget?

9 Divide \$61.92 between 4 people.

10 Dress material costs \$11.80 per metre. How many metres would \$70.80 buy?

11 0.25 kg of flour costs 86.5 cents. How much would 48 kg of flour cost?

12 A drink can holds 375 mL. How many litres of drink are there in a case of 24 cans?

WEEKLY TEST 17

1. $\$1.73 +$
 $\quad 2.00$
 $\quad \underline{15.75}$

2. $\$200.00 -$
 $\quad \underline{37.50}$

3. $\$4.71 \times 7$

4. $\$14.77 \div 7$

5. A shop is selling coffee mugs for 98c. How much for 10 mugs?

6. Make out and total this bill:

- 2 kg mushrooms at \$4.55 per kg,
- 20 kg potatoes at 54c per kg,
- 20 bananas at 10 for \$1.85,
- 24 apples at 6 for \$1.

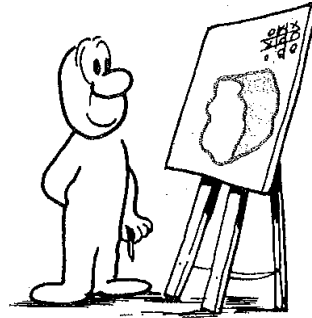

Looking back

7. Draw a sketch of a cylinder.
8. How many minutes in 3 hours?
9. Divide 963 by 9.
10. Without using calculators.
Copy and complete:

(a) the addition square

+	5	7	9
4			
6			
8			

(b) the multiplication square

×	5	7	9
4			
6			
8			

Classroom Unit 7

oo as in balloon oo as in flood
oo as in floor

The List							
roost	balloon	baboon	bamboo	cartoon	harpoon	lagoon	mushroom
igloo	cuckoo	monsoon	poodle	afternoon			
blood	flood		door	floor	moor	poor	

1 Use a dictionary to help you find the definitions of the following words . . .

moor _____
spoor _____
monsoon _____

2 Write a suitable **list** or **champs'** word in the gaps in these sentences.

- a By polishing the _____, the cleaner had made crossing from the kitchen to the hallway a slippery adventure.
- b We ate our lunch by the river and then spent the rest of the _____ exploring the riverbank.
- c In the _____ light it was difficult to see which _____ we should open to get into the house.
- d When their favourite _____ appeared on the television the children laughed loudly.
- e The hunter followed the animal's _____ until it disappeared into a thick forest of _____.

3 Which **list** or **champs'** words . . .

- a I am an ape _____ b I am a dog _____
- c I am a caterpillar's house _____ d I am an eskimo's house _____
- e I am a funny drawing _____ f I am an overflow of water _____
- g I am a fungus _____ h I am a pond of shallow water _____

4 Which **list** words contain 'smaller' words that mean . . . ?

- a a musical instrument _____ b the sound a cow makes _____
- c small vehicle which is pulled along _____ d a sphere _____

Word Building

Use the words in Group A combined with those in Group B to form **compound words**.

A	B	
after	room	_____
blood	light	_____
honey	board	_____
toad	moon	_____
bed	noon	_____
moon	way	_____
floor	thirsty	_____
trap	stool	_____
door	light	_____
flood	door	_____

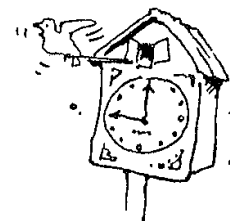

For Champs

cocoon bloodthirsty
spoor tattoo

Weekly Test Results:

__ out of 10, plus __ Bonus

Champs' Points = Total __

Home Study Unit 7

*He tramped away from the shanty there, when the days were long and hot,
 With never a soul to know or care if he died on the track or not.
 The poor of the city have friends in woe, no matter how much they lack,
 But only God - and the swagman know how a poor man fares Outback!*
 (Henry Lawson)

1 Write all of the **list** and **champs'** words ending in 'oor' in alphabetical order . . .

2 Match a **list** or **champs'** word with each illustration . . .

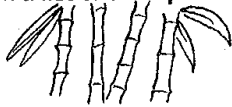

3 Write one interesting sentence containing: poor harpoon lagoon _____

4 Which word . . . ?

- a greater quantity (moor or more?) _____
- b not rich (poor, pour or pore?) _____
- c an animal track (spoor or spore?) _____
- d open area of land (moor or more?) _____
- e send flowing (poor, pour or pore?) _____
- f skin opening (poor, pour or pore?) _____

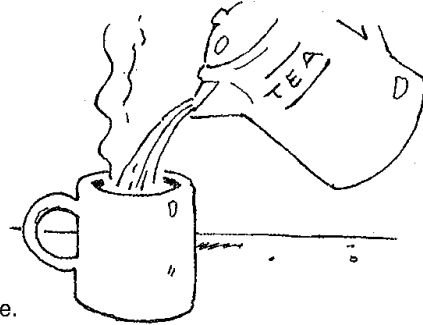

5 Unjumble the following **list** words and then write each in a sentence.

- d p l o e o _____
- n o m o s o n _____
- d o l o f _____

Vocabulary Extension

1 Use a dictionary to find the meaning of aloof and then write the word in a sentence to show its meaning.

2 Write each of the **champs'** words in a sentence.

- tattoo _____
- spoor _____
- cocoon _____
- bloodthirsty _____

General Knowledge What am I?

- 1 I am an African country. My population is around 9 million. My capital is Yaounde. _____
- 2 I am a small carnivorous mammal able to kill venomous snakes. _____
- 3 I am a Muslim of mixed Berber and Arab descent. I live in North-West Africa. M_____

All set for attack on TV-time snacks

A young mother walks down a supermarket aisle, tosses a bag of chips into her trolley and remarks, 'Okay, that's snacks for the kids' lunch box.'

It's not a joke. It's an advertisement watched repeatedly by children during after-school hours on Channel Ten yesterday, and one of dozens of commercials promoting junk food between 4 pm and 4.30 pm — prime time for school students.

Kaye Mehta, the chairwoman of the Coalition on Food Advertising to Children, said young viewers had rarely seen parental endorsement for junk food depicted in such an overt manner. 'Kids see this junk on television, they see small packages of junk in their lunch boxes, it becomes normality for them,' she said.

David Crawford, the co-ordinator of the Centre for Physical Activity and Nutrition Research at Deakin University, said his team had studied the viewing habits of more than 500 families. The study concluded that children who watched a lot of television were more likely 'to have a higher consumption of discretionary foods — snack foods they could hold in their hands that were more likely to be high in fat and sugar'.

But the research had not separated the effect of advertisements from that of overall television viewing. That question would be answered by two new studies.

Source J. Norrie, S. Creagh and J. Robotham, 'All set for attack on TV-time snacks', *Sydney Morning Herald*, 18 June 2004, p. 4.

The first, in collaboration with Sydney University, would look at the foods bought by hundreds of Sydney families and cross-reference them against the television ads they watched. In a second Victorian study, children would be shown food ads and their responses tested.

Clare Collins, a senior lecturer in nutrition and dietetics at the University of Newcastle, said government intervention over food advertising would be 'a long-term investment, just as programs to control smoking have been'.

Tube Junk Food

Channel Nine ad listing for 4 pm–4.30 pm yesterday

1. Kellogg's Froot Loops
2. Taronga Zoo with McDonald's
3. Philadelphia Cream Cheese
4. The reading writing hotline
5. The television show Hi-5
6. Cadbury's Freddo frogs
7. Water safety community announcement
8. Ribena fruit drink
9. Kellogg's Coco Pops
10. Philadelphia Cream Cheese
11. Seaworld Sea Watch
12. Kellogg's Froot Loops
13. Anudderworld — anti-bullying community service announcement

Questions

1. Why do you think commercials for junk food are often shown between 4.00 pm and 4.30 pm?
2. The study discussed in the article found that 'children who watch a lot of television were more likely to have a higher consumption of ... snack foods ... that were more likely to be high in fat and sugar'. Discuss possible reasons for this.
3. Why do you think Kay Mehta is concerned about the advertisement in which a young mother throws a bag of chips in a trolley and says, 'Okay, that's snacks for the kids' lunch box'?
4. Government laws should be used to control when and how junk food can be advertised on television. Discuss this statement, giving reasons for your opinion.

Unit 10.1

CALCULATOR CROSSNUMBER



Use your calculator to help you complete the crossnumber puzzle below.

Across:

1. 5^2
2. $\sqrt{289}$
3. $\sqrt{1849}$
4. 7^2
5. $\sqrt{196}$
6. 11^2
7. 32^2
11. $\sqrt{119^2 - 105^2}$
12. $\sqrt{9^2 + 12^2}$
13. $15^2 - 12^2$
15. $\sqrt{136^2 - 120^2}$
16. $8^2 + 2$
17. 31^2
19. $5^2 + 12^2$
21. $50^2 - 48^2$
22. $\sqrt{12^2 + 16^2}$
23. $\sqrt{10^2 + 24^2}$
24. $14^2 + 48^2$
25. $25^2 - 24^2$
26. $\sqrt{24^2 + 32^2}$
28. $12^2 - 2 \times 13$
31. $75^2 - 72^2$
33. $175^2 - 168^2$
34. $(20 - 1)^2$
36. $\sqrt{8^2 + 15^2}$
37. $\sqrt{5^2 + 12^2}$
38. $50^2 + 55^2$

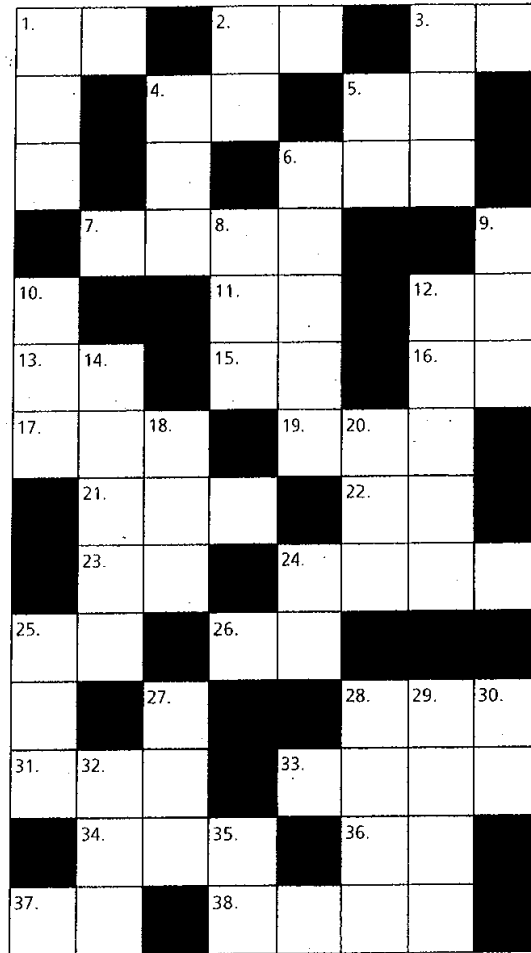

Down:

1. 17^2
2. $\sqrt{361}$
3. 21^2
4. 20^2
5. $\sqrt{15^2 - 9^2}$
6. 121^2
8. 16^2
9. $20^2 - 12^2$
10. $8^2 + 15^2$
12. 130^2
14. 127^2
18. $8^2 + 11^2 + 11$
20. $7^2 + 24^2$
24. $\sqrt{400}$
25. 22^2
27. $18^2 - (2^2 \times 2)$
28. $38^2 - 4^2 - 4^2$
29. $32^2 + 7^2 + 2$
30. $15^2 - 12^2$
32. $12^2 + 17^2$
35. $\sqrt{17^2 - 8^2}$

